



# Installing Hairpin Legs

## Round Table Applications

1. Turn your table top upside-down on a scratch free surface.
2. Calculate the distance between the legs using the formulas shown.
3. Position the tip of the leg 1" back from the edge of the table.
4. Mark the positions of the holes in the mounting plate with a marker.
5. Attach the hairpin legs with the screws provided. Please note that the screws provided are the proper length for 3/4" to 1.25" thick tops.
6. Flip your completed table over and enjoy!

[Click for Hairpin Leg Helpfuls](#)

### Positioning 3 Hairpin Legs

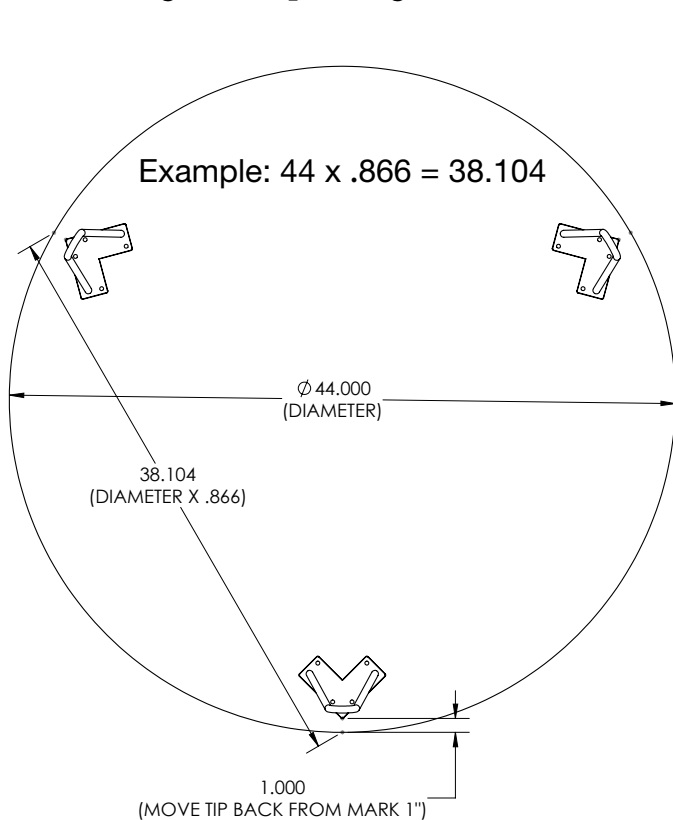

### Positioning 4 Hairpin Legs

